

# FIGURE 31 / 41 BRONZE SERIES

SIZES 1/2" – 2 1/2"  
PRESSURES to 300 PSIG at 422°F



**FIGURE 31 BRONZE SERIES**

## APPLICATION DATA

- Steam Boilers
- Pressure Reducing Stations
- Unfired Steam Pressure Vessels & Lines
- Accumulators, Sterilizers, Steam Cleaners
- Air compressors, Cookers, Receivers
- Pneumatic Systems
- OEM Equipment

## VALVE RATINGS *See Capacity Charts beginning on page 208*

Model	Pressure PSIG (bar)	Temperature °F (°C)
0031/0041/041A/41AT/41AA	5 to 250 (.3 to 17.2)	-20 to 406 (-29 to 208)
0032/0042/042A/42AT/42AA	5 to 300 (.3 to 20.7)	-20 to 422 (-29 to 216)
0033/0043/043A/43AT	5 to 250 (.3 to 17.2)	-20 to 406 (-29 to 208)

## APPLICABLE CODES

- ASME Section I "V" for Steam
- ASME Section VIII "UV" for Steam/Air/Gas
- API 527
- Canadian Registration # OG0591.9C
- PED (Consult Factory)

- Meets ASME Section I & VIII Code for Steam, Air & Non-hazardous Gas Service
- "V" or "UV" National Board Certified
- Dual Ring Control See page 206
- Rugged Cast Unitized Bonnet
- SS Spring Supplied as Standard
- Full Nozzle
- Soft Seat Design Available See page 206
- Open Lever Assembly

## OPTIONS

- Top Outlet Discharge
- BSP Connections
- Soft Seated Valves
- Plain Cap (on selected models)
- Test Reports Available

## MODELS

- 0031 - ASME Section I Steam, Bronze Trim
- 0041 - ASME Section VIII Steam, Bronze Trim
- 041A - ASME Section VIII Air, Bronze Trim
- 41AT - Top Outlet on 041A
- 41AA - Plain Cap on 041A (D orifice only)
- 0032 - SS Base & Disc on 0031
- 0042 - SS Base & Disc on 0041
- 042A - SS Base & Disc on 041A
- 42AT - SS Base & Disc on 41AT
- 42AA - SS Base & Disc on 41AA (D orifice only)
- 0033 - EPDM Soft Seat on 0031
- 0043 - EPDM Soft Seat on 0041
- 043A - Viton Soft Seat on 041A
- 43AT - Viton Soft Seat on 41AT

FIGURE 31 / 41  
BRONZE SERIES

## CODE SELECTION CHART

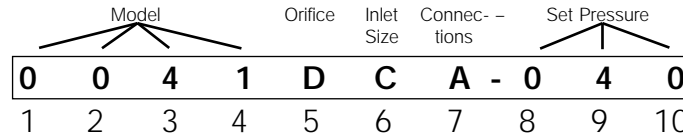

**Model** - Position 1, 2, 3 & 4  
 0031 = ASME Section I Steam, Bronze Trim  
 0041 = ASME Section VIII Steam, Bronze Trim  
 041A = ASME Section VIII Air, Bronze Trim  
 41AT = Top Outlet on 041A  
 41AA = Plain Cap on 041A (D orifice only)  
 0032 = SS Base & Disc on 0031  
 0042 = SS Base & Disc on 0041  
 042A = SS Base & Disc on 041A  
 42AT = SS Base & Disc on 41AT  
 42AA = SS Base & Disc on 41AA  
 0033 = EPDM Soft Seat on 0031  
 0043 = EPDM Soft Seat on 0041  
 043A = Viton Soft Seat on 041A  
 43AT = Viton Soft Seat on 41AT

**Orifice** - Position 5  
 D  
 E  
 F  
 G  
 H  
 J

**Inlet Size** - Position 6  
 C = 1/2  
 D = 3/4  
 E = 1  
 F = 1 1/4  
 G = 1 1/2  
 H = 2  
 J = 2 1/2

**Connections** - Position 7  
 A = MPT x FPT  
 E = MPT x Top  
 F = MBSP x FBSP  
 Z = Other

**Set Pressure** - Position 8, 9 & 10  
 \_ \_ \_ = Actual Setting  
 LAS - Loosely Assembled†

†Spence Certified Assemblers Only  
 (use 0031, 0032, 0033, 41AT, 42AT,  
 43AT, 41AA or 42AA only)

# FIGURE 31 / 41

## BRONZE SERIES

### SPECIFICATION

The valve shall meet the ASME Section I or VIII Code for steam, air and gas services. It shall be "V" or "UV" National Board Certified. The valve shall have dual blowdown ring to allow better adjustment of the pop and blowdown. The valve shall consist of a unitized bonnet design guaranteeing proper guiding and making the valve extremely dependable in terms of pop action, seat tightness and repeatability. The valve shall be top guided and shall have a full nozzle for optimum flow performance. The valve shall have a stainless steel spring for better corrosion and yield strength. The valve shall meet the API 527 leakage standard requiring bubble tight shutoff up to 90% of set pressure.

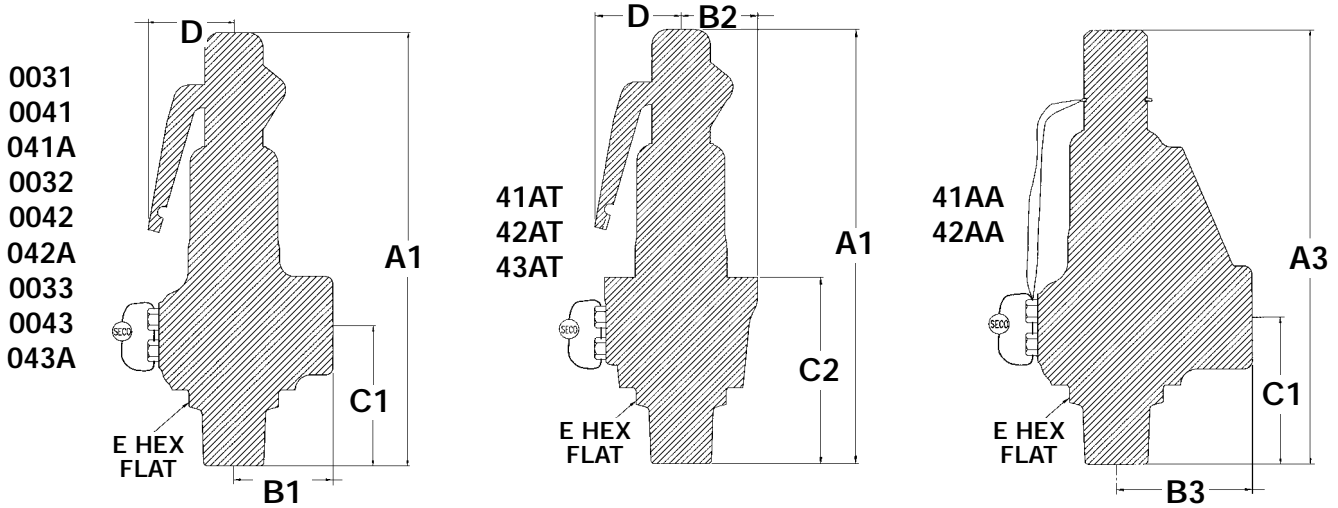

**DIMENSIONS\*** inches (mm) **AND WEIGHTS** pounds (kg)

Model	Inlet	Orifice	Outlet <sup>(2)</sup>	A1	A3	B1	B2	B3	C1	C2	D <sup>(1)</sup>	E	Weight
****DCA	½ MPT (15)	D	¾ FPT (20)	6⅞ (166.7)	6¼ (158.8)	1⅜ (34.9)	1⅞ (27.0)	1⅞ (47.6)	2¼ (57.2)	2⅞ (73.0)	1⅜ (34.9)	1⅞ (28.6)	2 (0.91)
****DDA	¾ MPT (20)	D	¾ FPT (20)	6⅞ (166.7)	6¼ (158.8)	1⅜ (34.9)	—	1⅞ (47.6)	2¼ (57.2)	—	1⅜ (34.9)	1¼ (31.8)	2¼ (1.02)
****EDA	¾ MPT (20)	E	1 FPT (25)	7⅞ (181.0)	—	1⅞ (41.3)	1¼ (31.8)	—	2⅝ (58.7)	3⅞ (79.4)	1⅞ (34.9)	1¼ (31.8)	2½ (1.13)
****EEA	1 MPT (25)	E	1 FPT (25)	7⅞ (181.0)	—	1⅞ (41.3)	—	—	2⅝ (58.7)	—	1⅞ (34.9)	1½ (38.1)	2¾ (1.25)
****FEA	1 MPT (25)	F	1¼ FPT (32)	9 (228.6)	—	1⅞ (47.6)	1⅞ (36.5)	—	2 13⁄16 (71.4)	3½ (88.9)	1 11⁄16 (42.9)	1½ (38.1)	4 (1.81)
****FFA	1¼ MPT (32)	F	1¼ FPT (32)	9 (228.6)	—	1⅞ (47.6)	—	—	2 13⁄16 (71.4)	—	1 11⁄16 (42.9)	1¾ (44.5)	4¼ (1.93)
****GFA	1¼ MPT (32)	G	1½ FPT (40)	9 11⁄16 (246.1)	—	2⅞ (54.0)	1 11⁄16 (42.9)	—	3 (76.2)	3¾ (95.3)	1 11⁄16 (42.9)	1⅞ (47.6)	7 (3.18)
****GGA	1½ MPT (40)	G	1½ FPT (40)	9 11⁄16 (246.1)	—	2⅞ (54.0)	—	—	3 (76.2)	—	1 11⁄16 (42.9)	2 5⁄16 (52.4)	7¼ (3.29)
****HGA	1½ MPT (40)	H	2 FPT (50)	12⅞ (308.0)	—	2⅞ (65.1)	2 5⁄16 (52.4)	—	3½ (88.9)	4 11⁄16 (119.1)	2¼ (69.9)	2¼ (57.2)	13½ (6.12)
****HHA	2 MPT (50)	H	2 FPT (50)	12⅞ (308.0)	—	2 5⁄16 (65.1)	—	—	3½ (88.9)	—	2¾ (69.9)	2 5⁄16 (65.1)	13¾ (6.24)
****JHA	2 MPT (50)	J	2½ FPT (65)	13 9⁄16 (338.1)	—	3⅞ (79.4)	2½ (63.5)	—	3¾ (95.3)	5 (127.0)	2¾ (69.9)	2¾ (69.9)	17½ (7.94)
****JJA	2½ MPT (65)	J	2½ FPT (65)	13 9⁄16 (338.1)	—	3⅞ (79.4)	—	—	3¾ (95.3)	—	2¾ (69.9)	3 (76.2)	17¾ (8.05)

\*Accurate to ±1/8".

\*\*\*\* Use appropriate Model Number.

<sup>(1)</sup> Add 50% to D Dimension when lever is pulled out to manually operate valve.

<sup>(2)</sup> Outlet connections do not apply for \*\*AT top outlet valve.

FIGURE 31 / 41  
BRONZE SERIES

# FIGURE 31 / 41 BRONZE SERIES SOFT SEATS

Safety Valves with metal seats will start to leak at 90% of set pressure. A Spence Safety Valve equipped with a soft seat seals on both the metal and soft seats (see illustration). As a result, it will not begin to leak until system pressure reaches 95% of set pressure, minimizing system energy loss.

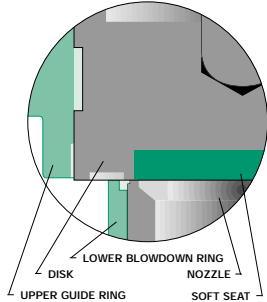

The o-rings in standard soft seat safety valves tend to blow out during discharge. Spence Soft Seat Safety Valves utilize a flat soft seat insert in the disc assembly of the valve that stays in place during operation, thus providing hassle-free operation.

There are many troublesome applications where using a Spence Soft Seat Safety Valve can reduce costly downtime and repair costs. Consider a Spence Soft Seat Safety Valve for:

- Operating very close to set pressure
- Heavy vibration
- Hard-to-hold fluids
- Occasional foreign particles
- Icing problems
- Pipe strain due to excessive discharge

## SERVICE RECOMMENDATIONS\*

### EPDM Soft Seat

**WET - -20 to 422°F (-29 to 216°C)**  
**DRY - -20 to 250°F (-29 to 121°C)**

Acetone	Freon 22
Acetylene Gas	Hydrazine
Beer	Lindol Hydraulic Fluid
Bleach Liquor	Lye
Brake Fluid	Methanol
Calcium Chloride	Methyl Alcohol
Carbon Monoxide	Methyl Butyl Ketone
Carbonic Acid	Nitrogen
Citric Acid	<b>STEAM</b>
Denatured Alcohol	Sulfur Hexafluoride
Ethylene Diamine	<b>WATER</b>

### Viton Soft Seat

**-20 to 400°F (-29 to 204°C)**

<b>AIR</b>	Dowtherm A	Iodine
Benzoic Acid	Ethane	Kerosene
Benzul Alcohol	Ethyl Alcohol	Linseed Oil
Butane	Ethyl Chloride	Methane
Butyl Alcohol	Ethylene	Mineral Oils
Carbon Disulfide	Ethylene Glycol	Natural Gas
Carbon Tetrachloride	Fuel Oil	Petroleum Oil
Castor Oil	Gasoline	Propane
Chlorine	Glucose	Propyl Alcohol
Chromic Acid	Glycerin	Propylene
Corn Oil	Helium	Sulfur Dioxide
Crude Oil	Hydraulic Oil	Turpentine
Diesel Oil	Hydrogen Gas	

\*These recommendations should be used as a guide only. It is the sole responsibility of the user to select suitable materials.

FIGURE 31 / 41  
BRONZE SERIES

# FIGURE 31 BRONZE SERIES DUAL RING CONTROL

Safety Valves are pressure relief devices actuated by inlet static pressure and characterized by rapid opening or "pop" action. The difference between Safety Valves from different manufacturers is how well they do this.

Spence Figure 31 Safety Valves have Dual Ring Control which allows for finer adjustment of the "popping" action and length of "blowdown". This allows exceptional flow efficiency and maximum lifting force while minimizing system energy loss.

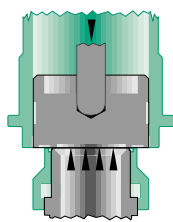

**CLOSED**

System pressure is pushing upward against the disk which is held closed by the downward force of the spring against the spindle.

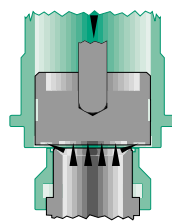

**OPENING**

When system pressure rises above the set pressure of the spring, the disc begins to lift. This simmer/warn stage allows system pressure to enter the "huddling chamber" where it acts on a larger, secondary area of the disc. This magnified force causes the valve to "pop" open.

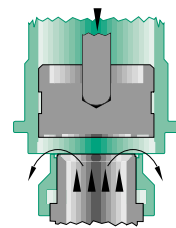

**OPEN**

As pressure increases, the disc continues to lift until fully open. When pressure is reduced to a level below the set point of the valve, the spring force against the spindle will snap shut the disc.



# FIGURE 31 / 41 BRONZE SERIES

## MATERIALS OF CONSTRUCTION

Ref	Part Name	Material
1A	Base/Nozzle - Bronze	Brass or Brz ASTM B283 or ASME SB62
1B	Base/Nozzle - SST	316 SST ASTM A276
2	Base Ring	Brass or Brz ASTM B283 or ASTM B62
3	Nozzle Ring Set Screw	Brass ASTM B16
4A	Disc - Bronze Metal	Brass or Brz ASTM B16 or ASTM B62
4B	Disc - SST Metal	316 SST ASTM A276
4C	Disc Assembly - Soft	Brass or Brz - EPDM/Viton
5	Guide Ring	Brass or Brz B283 or B584
6	Guide Ring Set Screw	Brass ASTM B16
7	Spindle	Steel ASTM A108
8	Spring	302 SST/17-7 SST
9	Spring Washer	Steel ASTM A108
10	Bonnet†	Cast Brz ASME SB62
11	Adjusting Bolt	Brass ASTM B16
12	Adjusting Bolt Locknut	Steel (Plated) SAE J995 GRD 2
13	Lifting Cap	Zinc Alloy
14	Lifting Cap Pin	Steel
15	Lifting Cap Lockscrew	Plated Steel
16	Spindle Nut	Steel ASTM
17	Spindle Nut Locknut	Plated Steel
18	Seal and Wire	Lead and SST
19	Nameplate	SST
20	Drive Screw	SST
21	Lever	Steel (Plated)

†41AT, 42AT, 43AT denoted by dotted line.

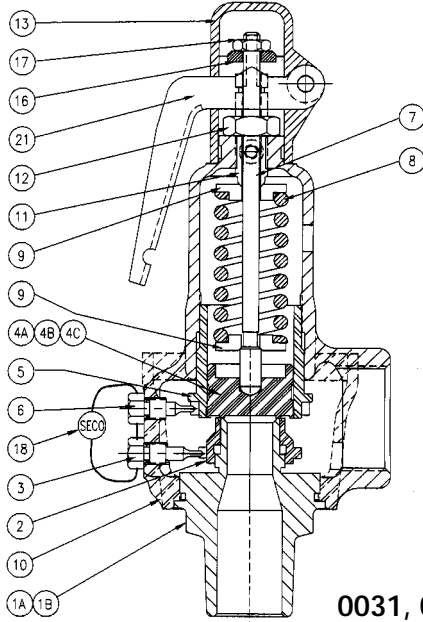
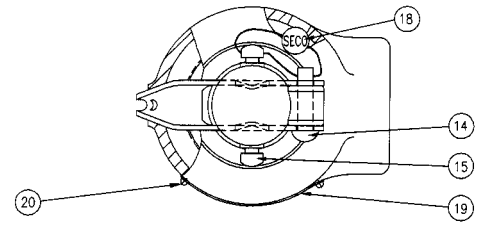

0031, 0041, 041A  
0032, 0042, 042A  
0033, 0043, 043A  
41AT, 42AT, 43AT

FIGURE 31 / 41  
BRONZE SERIES

Ref	Part Name	Material
1A	Base/Nozzle - Bronze	Brass ASTM B283
1B	Base/Nozzle - SST	316 SST ASTM A276
2	Base Ring	Brass ASTM B283
3	Nozzle Ring Set Screw	Brass ASTM B16
4A	Disc - Bronze Metal	Brass ASTM B16
4B	Disc - SST Metal	316 SST ASTM A276
5	Guide Ring	Brass B283
6	Guide Ring Set Screw	Brass ASTM B16
7	Spindle	Steel ASTM A108
8	Spring	302 SST/17-7 SST
9	Spring Washer	Steel ASTM A108
10	Bonnet	Cast Brz ASME SB62
11	Adjusting Bolt	Brass ASTM B16
12	Adjusting Bolt Locknut	Steel (Plated) SAE J995 GRD 2
13	Cap	Brass ASTM B16
18	Seal and Wire	Lead and SST
19	Nameplate	SST
20	Drive Screw	SST

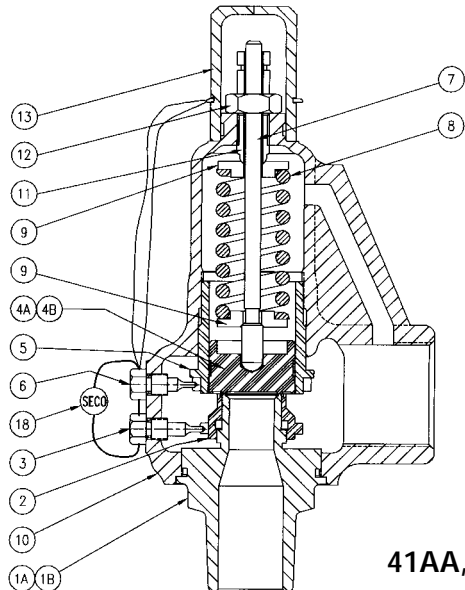
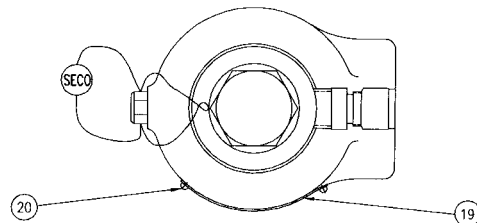

41AA, 42AA

# SATURATED STEAM CAPACITY CHART

## BRONZE MODELS 31, 32, 33

ASME Section I V" 90% rated at 3% Overpressure LBS/HR (KGS/HR)  
 Flow Coefficient = .9 x .975 = .878

LBS/HR

KGS/HR

Set Pressure PSIG	Orifice Area in <sup>2</sup>					
	D 0.1188	E 0.2116	F 0.3318	G 0.5424	H 0.8479	J 1.391
5 *	116	207	325	532	831	1364
10 *	143	255	400	654	1023	1678
15	170	303	475	776	1213	1991
20	197	351	550	899	1405	2305
25	224	398	625	1021	1596	2619
30	250	446	700	1144	1788	2933
35	277	494	774	1266	1979	3247
40	304	542	849	1388	2171	3561
45	331	589	924	1511	2362	3875
50	358	637	999	1633	2553	4189
55	385	685	1074	1756	2745	4503
60	411	733	1149	1878	2936	4817
65	438	780	1224	2001	3128	5131
70	466	829	1300	2126	3323	5451
75	493	878	1377	2252	3520	5774
80	521	928	1455	2378	3717	6098
85	548	977	1532	2504	3914	6421
90	576	1026	1609	2630	4111	6745
95	604	1075	1686	2756	4308	7068
100	631	1124	1763	2882	4506	7392
105	659	1174	1840	3008	4703	7715
110	687	1223	1917	3134	4900	8038
115	714	1272	1995	3261	5097	8362
120	742	1321	2072	3387	5294	8685
125	769	1370	2149	3513	5491	9009
130	797	1420	2226	3639	5688	9332
135	825	1469	2303	3765	5886	9655
140	852	1518	2380	3891	6083	9979
145	880	1567	2457	4017	6280	10302
150	908	1616	2535	4143	6477	10626
155	935	1666	2612	4269	6674	10949
160	963	1715	2689	4396	6871	11273
165	990	1764	2766	4522	7068	11596
170	1018	1813	2843	4648	7266	11919
175	1046	1862	2920	4774	7463	12243
180	1073	1912	2997	4900	7660	12566
185	1101	1961	3075	5026	7857	12890
190	1128	2010	3152	5152	8054	13213
195	1156	2059	3229	5178	8251	13537
200	1184	2108	3306	5404	8448	13860
205	1211	2158	3383	5531	8646	14183
210	1239	2207	3460	5657	8843	14509
215	1267	2256	3538	5783	9040	14830
220	1294	2305	3615	5909	9237	15154
225	1322	2354	3692	6035	9434	15477
230	1349	2404	3769	6161	9631	15800
235	1377	2453	3846	6287	9829	16124
240	1405	2502	3923	6413	10026	16447
245	1432	2551	4000	6540	10223	16771
250	1460	2600	4078	6666	10420	17094
255	1488	2650	4155	6792	10617	17418
260	1515	2699	4232	6918	10814	17741
265	1543	2748	4309	7044	11011	18064
270	1570	2797	4386	7170	11209	18388
275	1598	2846	4463	7296	11406	18711
280	1626	2896	4540	7422	11603	19035
285	1653	2945	4618	7548	11800	19358
290	1681	2994	4695	7675	11997	19682
295	1709	3043	4772	7801	12194	20005
300	1736	3092	4849	7927	12391	20328
1.0	6	10	15	25	39	65

Set Pressure Barg	Orifice Area cm <sup>2</sup>					
	D .766	E 1.365	F 2.141	G 3.499	H 5.47	J 8.974
0.4*	55	97	153	250	391	641
0.6*	62	110	173	282	441	723
0.8*	69	123	192	314	491	806
1*	76	135	212	346	542	889
1.2	83	148	232	379	592	971
1.4	90	160	251	411	642	1054
1.6	97	173	271	443	693	1136
1.8	104	185	291	475	743	1219
2	111	198	310	508	793	1302
2.2	118	211	330	540	844	1384
2.4	125	223	350	572	894	1467
2.6	132	236	370	604	944	1549
2.8	139	248	389	636	995	1632
3	146	261	409	669	1045	1715
3.2	153	273	429	701	1095	1797
3.4	161	286	448	733	1146	1880
3.6	168	299	468	765	1196	1962
3.8	175	311	488	797	1247	2045
4	182	324	507	830	1297	2128
4.2	189	336	527	862	1347	2210
4.4	196	349	547	894	1398	2293
4.6	203	361	567	926	1448	2375
4.8	210	374	587	959	1500	2460
5	217	387	607	993	1552	2545
5.2	225	400	627	1026	1603	2631
5.4	232	413	648	1059	1655	2716
5.6	239	426	668	1092	1707	2801
5.8	246	439	688	1125	1759	2886
6	254	452	709	1158	1811	2971
6.5	272	484	759	1241	1941	3184
7	290	517	810	1324	2070	3396
7.5	308	549	861	1407	2200	3609
8	326	581	912	1490	2329	3822
8.5	345	614	962	1573	2459	4034
9	363	646	1013	1656	2589	4247
9.5	381	678	1064	1739	2718	4460
10	399	711	1114	1822	2848	4672
10.5	417	743	1165	1905	2978	4885
11	435	775	1216	1988	3107	5098
11.5	454	808	1267	2071	3237	5310
12	472	840	1317	2154	3367	5523
12.5	490	873	1368	2237	3496	5736
13	508	905	1419	2319	3626	5948
13.5	526	937	1470	2402	3756	6161
14	544	970	1520	2485	3885	6374
14.5	563	1002	1571	2568	4015	6586
15	581	1034	1622	2651	4144	6799
15.5	599	1067	1673	2734	4274	7012
16	617	1099	1723	2817	4404	7224
16.5	635	1131	1774	2900	4533	7437
17	653	1164	1825	2983	4663	7650
17.5	672	1196	1875	3066	4793	7862
18	690	1228	1926	3149	4922	8075
18.5	708	1261	1977	3232	5052	8288
19	726	1293	2028	3315	5182	8500
19.5	744	1325	2078	3398	5311	8713
20	762	1358	2129	3481	5441	8926
20.5	780	1390	2180	3563	5571	9139
21	799	1423	2231	3646	5700	9351
21.5	817	1455	2281	3729	5830	9564
0.1	3.6	6.4	10.1	16.6	25.9	42.5

BRONZE SERIES  
STEAM CAPACITY

\* Pressure settings below 15 PSIG (1.034 barg) are non code.



# SATURATED STEAM CAPACITY CHART

## BRONZE MODELS 41, 42, 43

ASME Section VIII "UV" 90% rated at 10% Overpressure LBS/HR (KGS/HR)  
 Flow Coefficient = .9 x .975 = .878

LBS/HR

KGS/HR

Set Pressure PSIG	Orifice Area in <sup>2</sup>					
	D 0.1188	E 0.2116	F 0.3318	G 0.5424	H 0.8479	J 1.391
5 *	122	217	341	557	870	1428
10 *	149	265	416	679	1062	1742
15	176	313	491	802	1254	2057
20	203	361	566	925	1445	2371
25	229	409	641	1047	1637	2686
30	256	456	716	1170	1829	3000
35	286	509	798	1305	2040	3346
40	315	562	881	1440	2251	3692
45	345	614	963	1575	2461	4038
50	374	667	1046	1709	2672	4384
55	404	720	1128	1844	2883	4730
60	434	772	1211	1979	3094	5076
65	463	825	1293	2114	3305	5422
70	493	877	1376	2249	3516	5768
75	522	930	1458	2384	3727	6114
80	552	983	1541	2519	3937	6460
85	581	1035	1623	2654	4148	6805
90	611	1088	1706	2789	4359	7151
95	640	1140	1788	2923	4570	7497
100	670	1193	1871	3058	4781	7843
105	699	1246	1953	3193	4992	8189
110	729	1298	2036	3328	5203	8535
115	758	1351	2118	3463	5414	8881
120	788	1404	2201	3598	5624	9227
125	818	1456	2283	3733	5835	9573
130	847	1509	2366	3868	6046	9919
135	877	1561	2448	4003	6257	10265
140	906	1614	2531	4137	6468	10611
145	936	1667	2614	4272	6679	10957
150	965	1719	2696	4407	6890	11303
155	995	1772	2779	4542	7100	11648
160	1024	1825	2861	4677	7311	11994
165	1054	1877	2944	4812	7522	12340
170	1083	1930	3026	4947	7733	12686
175	1113	1982	3109	5082	7944	13032
180	1143	2035	3191	5217	8155	13378
185	1172	2088	3274	5352	8366	13724
190	1202	2140	3356	5486	8577	14070
195	1231	2193	3439	5621	8787	14416
200	1261	2246	3521	5756	8998	14762
205	1290	2298	3604	5891	9209	15108
210	1320	2351	3686	6026	9420	15454
215	1349	2403	3769	6161	9631	15800
220	1379	2456	3851	6296	9842	16146
225	1408	2509	3934	6431	10053	16492
230	1438	2561	4016	6566	10263	16837
235	1468	2614	4099	6700	10474	17183
240	1497	2667	4181	6835	10685	17529
245	1527	2719	4264	6970	10896	17875
250	1556	2772	4346	7105	11107	18221
255	1586	2824	4429	7240	11318	18567
260	1615	2877	4511	7375	11529	18913
265	1645	2930	4594	7510	11740	19259
270	1674	2982	4676	7645	11950	19605
275	1704	3035	4759	7780	12161	19951
280	1733	3088	4841	7914	12372	20297
285	1763	3140	4924	8049	12583	20643
290	1793	3193	5007	8184	12794	20989
295	1822	3245	5089	8319	13005	21335
300	1852	3298	5172	8454	13216	21681
1.0	6.0	10.5	16.5	27.0	42.2	69

Set Pressure Barg	Orifice Area cm <sup>2</sup>					
	D .766	E 1.365	F 2.141	G 3.499	H 5.47	J 8.974
0.4*	57	102	160	261	409	670
0.6*	64	115	180	294	459	753
0.8*	71	127	199	326	509	836
1*	78	140	219	358	560	918
1.2	86	152	239	390	610	1001
1.4	93	165	259	423	661	1084
1.6	100	177	278	455	711	1167
1.8	107	190	298	487	762	1249
2	114	203	318	519	812	1332
2.2	121	216	339	554	866	1420
2.4	129	230	360	589	921	1511
2.6	137	244	382	625	977	1602
2.8	145	258	404	660	1032	1693
3	152	271	426	696	1088	1784
3.2	160	285	447	731	1143	1875
3.4	168	299	469	767	1199	1966
3.6	176	313	491	802	1254	2057
3.8	183	327	512	838	1309	2148
4	191	341	534	873	1365	2239
4.2	199	354	556	909	1420	2330
4.4	207	368	578	944	1476	2421
4.6	215	382	599	980	1531	2512
4.8	222	396	621	1015	1587	2603
5	230	410	643	1051	1642	2694
5.2	238	424	664	1086	1698	2785
5.4	246	438	686	1122	1753	2876
5.6	253	451	708	1157	1809	2967
5.8	261	465	729	1192	1864	3058
6	269	479	751	1228	1920	3149
6.2	277	493	773	1263	1975	3240
6.4	284	507	795	1299	2031	3331
6.6	292	521	816	1334	2086	3422
7	308	548	860	1405	2197	3604
7.5	327	583	914	1494	2336	3832
8	347	617	968	1583	2474	4059
8.5	366	652	1022	1671	2613	4287
9	386	687	1077	1760	2752	4514
9.5	405	721	1131	1849	2890	4742
10	424	756	1185	1938	3029	4969
10.5	444	790	1240	2026	3168	5196
11	463	825	1294	2115	3306	5424
11.5	483	860	1348	2204	3445	5651
12	502	894	1402	2292	3584	5879
12.5	522	929	1457	2381	3722	6106
13	541	964	1511	2470	3861	6334
13.5	560	998	1565	2559	4000	6561
14	580	1033	1619	2647	4138	6789
14.5	599	1067	1674	2736	4277	7016
15	619	1102	1728	2825	4416	7244
15.5	638	1137	1782	2913	4554	7471
16	658	1171	1836	3002	4693	7699
16.5	677	1206	1891	3091	4832	7926
17	696	1240	1945	3179	4970	8154
17.5	716	1275	1999	3268	5109	8381
18	735	1310	2053	3357	5248	8609
18.5	755	1344	2108	3446	5386	8836
19	774	1379	2162	3534	5525	9064
19.5	794	1413	2216	3623	5664	9291
20	813	1448	2271	3712	5802	9519
20.5	832	1483	2325	3800	5941	9746
0.1	3.9	6.9	10.9	17.7	27.7	45.5

BRONZE SERIES  
STEAM CAPACITY

\* Pressure settings below 15 PSIG (1.034 barg) are non code.



# AIR CAPACITY CHART

BRONZE MODELS 41A, 42A, 43A, 41AT, 42AT, 43AT, 41AA, 42AA

ASME Section VIII "UV" 90% rated at 10% Overpressure SCFM (M<sup>3</sup>/HR)  
Flow Coefficient = .9 x .975 = .878

SCFM

Set Pressure PSIG	Orifice Area in <sup>2</sup>					
	D	E	F	G	H	J
	0.1188	0.2116	0.3318	0.5424	0.8479	1.391
5 *	43	77	121	198	310	508
10 *	53	94	148	242	378	620
15	63	111	175	285	446	732
20	72	128	201	329	514	844
25	82	145	228	373	583	956
30	91	162	255	416	651	1068
35	102	181	284	464	726	1191
40	112	200	313	512	801	1314
45	123	219	343	560	876	1437
50	133	237	372	608	951	1560
55	144	256	402	656	1026	1684
60	154	275	431	704	1101	1807
65	165	294	460	753	1176	1930
70	175	312	490	801	1251	2053
75	186	331	519	849	1326	2176
80	196	350	548	897	1402	2299
85	207	368	578	945	1477	2422
90	217	387	607	993	1552	2545
95	228	406	637	1041	1627	2669
100	238	425	666	1089	1702	2792
105	249	443	695	1137	1777	2915
110	259	462	725	1185	1852	3038
115	270	481	754	1233	1927	3161
120	280	500	783	1281	2002	3284
125	291	518	813	1329	2077	3407
130	302	537	842	1377	2152	3531
135	312	556	872	1425	2227	3654
140	323	575	901	1473	2302	3777
145	333	593	930	1521	2377	3900
150	344	612	960	1569	2452	4023
155	354	631	989	1617	2527	4146
160	365	649	1018	1665	2602	4269
165	375	668	1048	1713	2677	4392
170	386	687	1077	1761	2753	4516
175	396	706	1106	1809	2828	4639
180	407	724	1136	1857	2903	4762
185	417	743	1165	1905	2978	4885
190	428	762	1195	1953	3053	5008
195	438	781	1224	2001	3128	5131
200	449	799	1253	2049	3203	5254
205	459	818	1283	2097	3278	5378
210	470	837	1312	2145	3353	5501
215	480	855	1341	2193	3428	5624
220	491	874	1371	2241	3503	5747
225	501	893	1400	2289	3578	5870
230	512	912	1430	2337	3653	5993
235	522	930	1459	2385	3728	6116
240	533	949	1488	2433	3803	6239
245	543	968	1518	2481	3878	6363
250	554	987	1547	2529	3953	6486
255	564	1005	1576	2577	4028	6609
260	575	1024	1606	2625	4104	6732
265	585	1043	1635	2673	4179	6855
270	596	1062	1665	2721	4254	6978
275	606	1080	1694	2769	4329	7101
280	617	1099	1723	2817	4404	7224
285	628	1118	1753	2865	4479	7348
290	638	1136	1782	2913	4554	7471
295	649	1155	1811	2961	4629	7594
300	659	1174	1841	3009	4704	7717
1.0	2.2	3.6	6.0	9.6	15.0	24.6

M<sup>3</sup>/HR

Set Pressure Barg	Orifice Area cm <sup>2</sup>					
	D	E	F	G	H	J
	.766	1.365	2.141	3.499	5.47	8.974
0.4*	76	136	213	349	545	894
0.6*	86	153	240	392	612	1004
0.8*	95	170	266	435	679	1114
1*	105	186	292	478	747	1225
1.2	114	203	318	521	814	1335
1.4	123	220	345	564	881	1445
1.6	133	237	371	607	948	1556
1.8	142	253	397	650	1016	1666
2	152	270	424	693	1083	1776
2.2	162	288	452	738	1154	1894
2.4	172	307	481	786	1228	2015
2.6	182	325	510	833	1302	2137
2.8	193	343	539	880	1376	2258
3	203	362	568	928	1450	2379
3.2	214	380	596	975	1524	2501
3.4	224	399	625	1022	1598	2622
3.6	234	417	654	1070	1672	2743
3.8	245	436	683	1117	1746	2865
4	255	454	712	1164	1820	2986
4.2	265	473	741	1212	1894	3107
4.4	276	491	770	1259	1968	3229
4.6	286	510	799	1306	2042	3350
4.8	296	528	828	1354	2116	3471
5	307	547	857	1401	2190	3593
5.2	317	565	886	1448	2264	3714
5.4	328	583	915	1496	2338	3835
5.6	338	602	944	1543	2412	3957
5.8	348	620	973	1590	2486	4078
6	359	639	1002	1637	2560	4199
6.2	369	657	1031	1685	2634	4321
6.4	379	676	1060	1732	2708	4442
6.6	390	694	1088	1779	2782	4563
7	410	731	1146	1874	2930	4806
7.5	436	777	1219	1992	3114	5109
8	462	823	1291	2111	3299	5413
8.5	488	870	1363	2229	3484	5716
9	514	916	1436	2347	3669	6019
9.5	540	962	1508	2465	3854	6323
10	566	1008	1581	2584	4039	6626
10.5	592	1054	1653	2702	4224	6929
11	618	1100	1725	2820	4409	7233
11.5	644	1146	1798	2939	4594	7536
12	670	1193	1870	3057	4779	7839
12.5	695	1239	1942	3175	4964	8143
13	721	1285	2015	3293	5148	8446
13.5	747	1331	2087	3412	5333	8749
14	773	1377	2159	3530	5518	9053
14.5	799	1423	2232	3648	5703	9356
15	825	1469	2304	3767	5888	9659
15.5	851	1516	2376	3885	6073	9963
16	877	1562	2449	4003	6258	10266
16.5	903	1608	2521	4121	6443	10570
17	929	1654	2594	4240	6628	10873
17.5	955	1700	2666	4358	6813	11176
18	980	1746	2738	4476	6998	11480
18.5	1006	1792	2811	4595	7182	11783
19	1032	1839	2883	4713	7367	12086
19.5	1058	1885	2955	4831	7552	12390
20	1084	1931	3028	4949	7737	12693
20.5	1110	1977	3100	5068	7922	12996
0.1	5.2	9.2	14.5	23.6	37	60.7

BRONZE SERIES AIR CAPACITY

\* Pressure settings below 15 PSIG (1.034 barg) are non code.





**FIGURE 31 CAST IRON SERIES**

# FIGURE 31 / 41 CAST IRON SERIES

SIZES 1 1/2" – 6"  
PRESSURES to 250 PSIG at 406°F

- Meets ASME Section I & VIII Code for Steam, Air & Non-hazardous Gas Service
- "V" or "UV" National Board Certified
- Dual Ring Control See page 206
- Heavy Duty Construction
- Flanged or Threaded Connections
- SS Trim Design Available
- Heavy Duty Open Lever Assembly

## OPTIONS

- SS Trim
- BSP Connections
- Test Reports Available

## MODELS

- 0031 - ASME Section I Steam, Bronze Trim
- 0041 - ASME Section VIII Steam, Bronze Trim
- 041A - ASME Section VIII Air, Bronze Trim
- 0032 - SS Base & Disc on 0031
- 0042 - SS Base & Disc on 0041
- 042A - SS Base & Disc on 041A

## APPLICABLE CODES

- ASME Section I "V" for Steam
- ASME Section VIII "UV" for Steam/Air/Gas
- API 527
- Canadian Registration # OG0591.9C

## APPLICATION DATA

- Steam Boilers
- Pressure Reducing Stations
- Unfired Steam Pressure Vessels & Lines
- Air compressors, Cookers, Receivers
- Pneumatic Systems
- OEM Equipment

## VALVE RATINGS *See Capacity Charts beginning on page 215*

Model	Pressure PSIG (bar)	Temperature °F (°C)
All	5 to 250 (.3 to 17.2)	-20 to 406 (-29 to 208)

## CODE SELECTION CHART

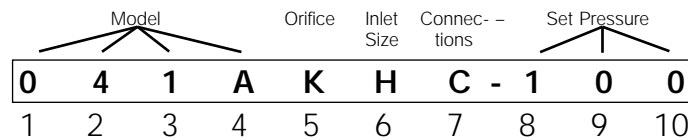

### Model -

Position 1, 2, 3 & 4

- 0031 = ASME Section I Steam, Bronze Trim
- 0041 = ASME Section VIII Steam, Bronze Trim
- 041A = ASME Section VIII Air, Bronze Trim
- 0032 = SS Base & Disc on 0031
- 0042 = SS Base & Disc on 0041
- 042A = SS Base & Disc on 041A

### Orifice -

Position 5

- J
- K
- L
- M
- N
- P
- Q
- R

### Inlet Size -

Position 6

- G = 1 1/2
- H = 2
- J = 2 1/2
- K = 3
- M = 4
- P = 6

### Connections -

Position 7

- B = FPT x FPT
- C = 250# x FPT
- D = 250# x 125#
- Z = Other

### Set Pressure -

Position 8, 9 & 10

- \_\_\_ = Actual Setting
- LAS - Loosely Assembled†

†Spence Certified Assemblers Only  
(use 0031 or 0032 only)



# FIGURE 31 / 41 CAST IRON SERIES

## SPECIFICATION

The valve shall meet the ASME Section I or VIII Code for steam, air and gas services. It shall be "V" or "UV" National Board Certified. The valve shall have dual blowdown ring to allow better adjustment of the pop and blowdown. The valve shall be top guided and shall have a semi nozzle for optimum flow performance. The valve shall have an open lever assembly. The valve shall meet the API 527 leakage standard requiring bubble tight shutoff up to 90% of set pressure.

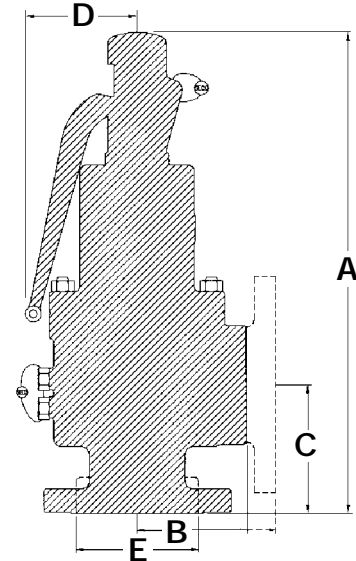

0031, 0041, 041A  
0032, 0042, 042A

### DIMENSIONS\* inches (mm) AND WEIGHTS pounds (kg)

Model	Inlet	Orifice	Outlet	A	B	C	D <sup>(1)</sup>	E	Weight
****JGB	1½" FPT (40)	J	2½" FPT (65)	15⅞ (384.2)	3½ (88.9)	4¼ (108)	3 (76.2)	¾ (82.6)	29 (13.2)
****JGC	1½" 250# (40)	J	2½" FPT (65)	15⅞ (384.2)	3½ (88.9)	4¼ (108)	3 (76.2)	—	36 (16.3)
****JHC	2" 250# (50)	J	3" FPT (80)	15¾ (400.1)	4 (101.6)	45/8 (117.5)	3½ (88.9)	—	42 (19.1)
****KHB	2" FPT (50)	K	3" FPT (80)	15¾ (400.1)	4 (101.6)	4⅝ (117.5)	3½ (88.9)	¾ (92.1)	36 (16.3)
****KHC	2" 250# (50)	K	3" FPT (80)	15¾ (400.1)	4 (101.6)	4⅝ (117.5)	3½ (88.9)	—	42 (19.1)
****KJC	2½" 250# (65)	K	3" FPT (80)	15¾ (400.1)	4 (101.6)	4¾ (120.7)	3½ (88.9)	—	45 (20.4)
****LJB	2½" FPT (65)	L	4" FPT (100)	23 <sup>(2)</sup> (584.2)	5⅞ (130.2)	5½ (139.7)	6 (152.4)	4½ (114.3)	97 (44.0)
****LJC	2½" 250# (65)	L	4" FPT (100)	23 <sup>(2)</sup> (584.2)	5⅞ (130.2)	5½ (139.7)	6 (152.4)	—	105 (47.6)
****KKC	3" 250# (80)	K	3" FPT (80)	15¾ (400.1)	4 (101.6)	5 (127)	3½ (88.9)	—	48 (21.8)
****LKC	3" 250# (80)	L	4" FPT (100)	23 <sup>(2)</sup> (584.2)	5⅞ (130.2)	5½ (139.7)	6 (152.4)	—	107 (48.5)
****MKB	3" FPT (80)	M	4" FPT (100)	23⅞ <sup>(2)</sup> (587.4)	5⅞ (130.2)	55/8 (142.9)	6 (152.4)	4½ (114.3)	99 (44.9)
****MKC	3" 250# (80)	M	4" FPT (100)	23 <sup>(2)</sup> (584.2)	5⅞ (130.2)	5½ (139.7)	6 (152.4)	—	107 (48.5)
****NMD	4" 250# (100)	N	6" 125# (150)	29⅞ <sup>(2)</sup> (749.3)	7¼ (184.2)	6⅝ (171.5)	6 (152.4)	—	215 (97.5)
****PMD	4" 250# (100)	P	6" 125# (150)	29⅞ <sup>(2)</sup> (749.3)	7¼ (184.2)	6⅝ (171.5)	6 (152.4)	—	215 (97.5)
****QPD <sup>(2)</sup>	6" 250# (150)	Q	8" 125# (200)	39⅞ <sup>(2)</sup> (1003.3)	10 (254)	9¼ (235)	10½ (266.7)	—	605 (274.4)
****RPD <sup>(2)</sup>	6" 250# (150)	R	8" 125# (200)	39⅞ <sup>(2)</sup> (1003.3)	10 (254)	9¼ (235)	10½ (266.7)	—	605 (274.4)

\*Accurate to ±1/8".

\*\*\*\* Use appropriate Model Number.

<sup>(1)</sup> Add 50% to D Dimension when lever is pulled out to manually operate valve.

<sup>(2)</sup> Dimensions are current as of printing, consult factory for updated dimensions as they may change.

FIGURE 31 / 41  
CAST IRON SERIES

# FIGURE 31 / 41 CAST IRON SERIES

## MATERIALS OF CONSTRUCTION

Ref	Part Name	Material
1	Body	Cast Iron ASTM A126-B
2	Bonnet	Cast Iron ASTM A126-B
3A	Nozzle - Bronze	Brass or Bronze ASTM B16 or B62
3B	Nozzle - SST	SST ASME SA351, CF8M or ASME SA479, S31600
4	Nozzle Ring	Bronze ASTM B584-C84400
5A	Disc - Bronze	Brass or Bronze ASTM B16 or B62
5B	Disc - SST	SST ASTM A479, S31600
6	Guide Ring	ASTM B584-C84400
7	Adjusting Bolt	Brass ASTM B16
8	Adjusting Bolt Locknut	Steel, Zinc Plated
9	Nozzle Ring Set Screw	Brass ASTM B16
10	Guide Ring Set Screw	Brass ASTM B16
11	Spindle	Steel ASTM A108 Grade 1212
12	Spindle Nut	Steel ASTM A108 Grade 1212
13	Spindle Nut Locknut	Steel, Zinc Plated
14	Lifting Cap	Zinc Alloy Zamac #3
15	Lifting Cap Pins	Steel, Zinc Plated AISI 1020
16	Pivot Post	Steel AISI 1020
17	Post Pin	Steel, Zinc Plated AISI 1070
18	Spring Washer	Steel AISI 1212
19	Spring	Steel Zinc Plated
20	Stud	Steel, Chrome-Moly ASTM A193 B7
21	Stud Nut	Steel, Chrome-Moly ASTM A194 2H
22	Nameplate	SST AISI 304
23	Nameplate Screws	SST Commercial 18-8
24	Lead Seal	Lead
25	Seal Wire	SST AISI 304
26	Lifting Cap	Cast Iron A126-B*
27	Lifting Lever	Cast Iron ASTM A126-B
28	Clevis Pin	Steel, Zinc Plated
29	Cotter Pin	Steel
30	Liftcap Lockscrew	Steel

\*Ductile Iron for 4" and above.  
ASTM A395 Grade 60-40-18

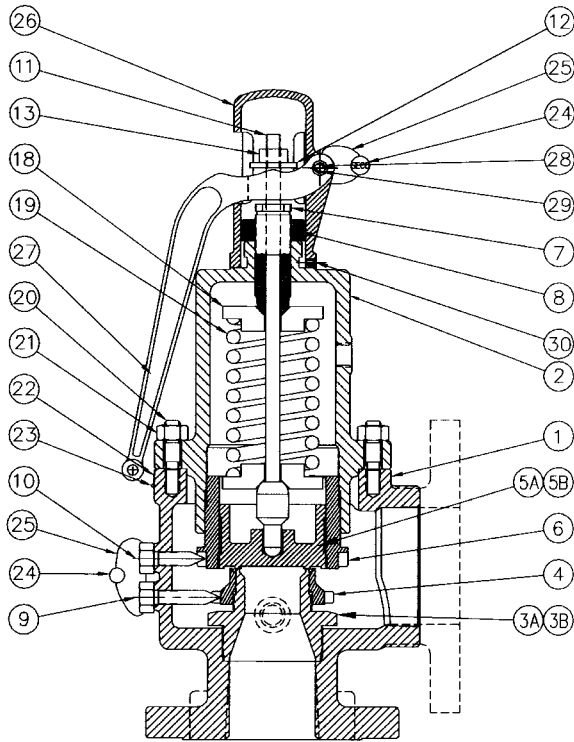
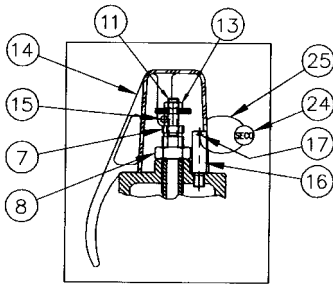

FIGURE 31 CAST IRON SERIES



CAP & LEVER CONFIGURATION  
FOR J & K ORIFICES

FIGURE 31 / 41  
CAST IRON SERIES





